

EZee Life™



Please read SAFETY INSTRUCTIONS
carefully before using the chair.

EZee Life™ Products
34 Futurity Gate, Unit 15, Concord, Ontario L4K 1S6

Function Introduction

The patented 4D soft massage machine in the back provides kneading, knocking, shiatsu and fast rubbing functions to create the composite kneading realized by human hand massage.

The heat function of the back massage roller radiates heat to the neck, shoulder and waist to help relax stressed muscles and promote blood circulation.

The super long rail design provides a multi angle massage from the neck to the thighs for a whole body massage experience.

The micro space slide function which slides the chair forward for use allows the chair to be positioned close to a wall when not in use.

The chair can be configured to lie flat for zero gravity positioning to provide relaxation for body and mind.

When used as the main remote control, the 7" PC tablet can display the massage position, method and status in real time and be used to customize the massage program in tandem with or independently from with the armrest control panel.

Blue tooth technology allows for more convenient operation through a smart phone or tablet PC.

The built-in MP3 player integrates music into the massage manipulation. The synced music and massage effectively helps adjust moods and relieves mental fatigue.

The omni-bearing rolling and air pressure massage installed in the foot area stimulates the foot reflexion zone with heat.

Multiple airbags in the leg areas perform pulse air pressure massage on the legs, promote blood circulation and restore leg vitality.

Air bags provide soft pulse air pressure massage on the arms to promote blood circulation.

Multiple sets of air bags in the waist and hip areas completely cover the waist, hip and thigh areas. The air pressure alternating squeezing function reduces fatigue.

The footrest can be adjusted within a 18 cm (7") range to fit a wide range of user heights.

Bluetooth Function: 1. download the appropriate Comtek APP to your smart phone or tablet. 2. install the software 3. choose ROKOL-RK8900A and connect it. 4. Open the Comtek APP and control the chair.

Android: <https://www.factorydirectmedical.com/downloads/CH4000-Android-APP.apk>

iPhone/iPad: <https://itunes.apple.com/ca/app/massage-chair/id1018690700?mt=8>

Bluetooth Wireless Music: Connect your smartphone or tablet to the chair, open your music program and play the music.

Thank you for choosing the CH4000 lift chair from EZee Life.

Please read this manual carefully before using the chair.

Keep this manual for future reference.

Read and heed the safety information

Note: Small design modifications may occur from time to time and the illustrations in this manual are for reference only.

Contents

Preparation

Safety Instructions	1
External Structure	5
Internal Structure	6
Mechanical Components Diagram	7
Mechanical Components List	8

Installation

Installation	9
--------------	---

Massage Operation

Pre-Massage Adjustment	13
Manual Control	15
Operation Instruction & Function Illustration	21
Post Massage	24

Maintenance

Cleaning and Maintenance	25
--------------------------	----

Other Information

Malfunction Guide	26
Technical Data	27

Please retain the manual in a safe place for future reference

Safety Instructions

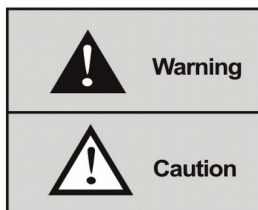

- Please read this manual carefully to ensure correct installation and operation of the chair
- Safety Instructions include both Warnings and Cautions for important aspects of using the chair. Please pay particular attention to Warning and Cautions.



This symbol warns of possible injury to a person

This symbol warns of possible damage to items

Other Symbol Meanings

Conditions & Situations Where the Chair Should Not Be Used	
	Users who suffer from osteoporosis
	People with heart disease, pacemakers or other electronic devices embedded in their bodies
	Pregnant or generally unhealthy users must consult a doctor before use
	Patients suffering from a fever
	Patients with perceptual disabilities
	Children or People over 80 years of age
	People impaired by alcohol or drugs
	People who may fall asleep in the chair
	People who are wet

Instructions to avoid accidents and injuries



Ensure there are no kids, pets or objects under, behind or in front of chair when adjusting the backrest or leg rest position

Discontinue use of you feel abnormal sensations during use

Do not use strong massage on the head

Do not massage belly or knees and use cation when massaging the neck



Do not allow children or pets on the chair (especially during a massage)

Do not sit or stand on armrests or backrest

Those who have difficulty moving or expressing themselves must be supervised at all times

Instructions to avoid fire and electrical shock



Insert the power cord fully into a suitable power outlet

Unplug the power cord when not in use

Stop all massage functions and turn off key before unplugging

Forbidden behaviour that may lead to accidental damage



Do not use the chair if ventilation holes are blocked

Do not fold the cushions

Do not run for extended periods of time with no load

Forbidden behaviour that may lead to fire or electrical shock



Do not use if power cord or plug is damaged

Using other than rated voltage may lead to damage, fire or shock

Do not use if any electrical cord is damaged, twisted, under stress

Disassembly and maintenance information



If the chair stops working, gets splashed or immersed in water have it repaired by a qualified repairperson. Self modification, repair or disassembly by the user is forbidden







Do not repair or replace a damaged power cord. Call a qualified serviceperson.





To avoid electric shock or injury do not disassemble any part of the chair. There are no user serviceable parts to the chair

Check for damage to the upholstery regularly and have any damage repaired. Unplug and cease using the chair until repaired



Important use instructions	
 	Set up and use the chair on flat, level, solid surface
	Position the chair at least 10 cm (4") from the wall or other item
	The maximum suggested operating time is 10 minutes. Five minutes for each position beginning with the slight step massage. Long continuous massages in the same position will lead to discomfort.
	Ensure the massage heads are in the correct position before sitting in the chair to avoid injury
	Ensure the power switch is in the off position before plugging in the power cord to avoid accidental injury
	Ensure the power cord plug is fully inserted into the wall outlet
	Ensure wires are undamaged and dry
Do not remove the ground prong on the power cord plug or use the chair if the prong has been removed	
Forbidden actions that may lead to accidents	
 	Do not exert pressure on massage heads with hands or feet
	Do not place hands between massage heads
	Do not place hands or feet in gaps between moving parts
	Do not drop or insert anything into slot of the massage chair
	Do not sit, stand or place heavy objects on the arm, back or footrest
	Do not stand on the chair seat
	Do not move the chair while operating
	Do not turn off chair or disconnect the power while the chair is operating
	Do not put any body part between or beneath legrests
	Do not use the chair while wearing hair ornaments
	Empty hard items from pockets before use
	Do not use with bare skin or too thin a material between the skin and upholstery. Skin irritation may occur if the body can't slide on the upholstery
	Protect the upholstery from fading, discolouration & hardening
 	Keep chair away from heat, moisture, sharp objects, corrosives, etc.
	Do not use an electric blanket on chair
	Do not use in environments with excessive dust, corrosive gases or inadequate ventilation and air circulation
	Avoid placing chair in direct sunlight
	Do not use outdoors

Other information	
	Do not use or store the chair in wet environments
	Keep the chair and the remote control dry at all times
	Ensure the chair is properly grounded
	Do not use a plug adapter. If the plug on the cord does not match you outlet have a qualified electrician change the outlet to match the cord.
	Unplug the chair before cleaning
	Unplug the chair after use
	Pull the plug, not the wire, to unplug the chair
	Turn off power switch and then unplug after use
	Unplug chair in case of power failure

Grounding Instructions

The chair is equipped with a cord having a ground wire. The plug must be plugged into an appropriate power outlet matching the plug.

Fuse Replacement

Turn off power and unplug chair before changing fuse.

The fuse is located under the fuse lid located between the power cord connector and the main on/off switch.

Replace the fuse with a fuse of equal size and amperage.

If in doubt, get the help of a qualified technician.

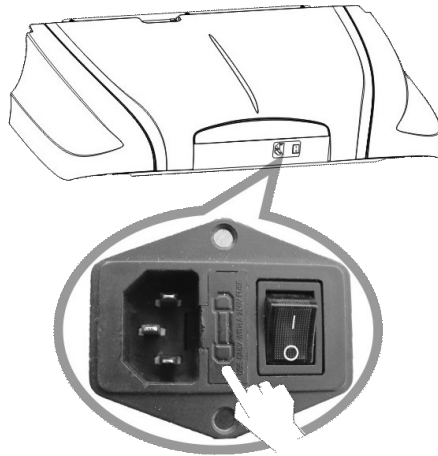

Ground wire connection prohibitions

	Connecting ground wire to gas pipe may lead to fire or explosion
	Connecting a ground wire to a phone line or lightning rod can cause fire or shock during a thunderstorm
	Connecting a ground wire to a plastic water pipe does not provide grounding protection





External structure

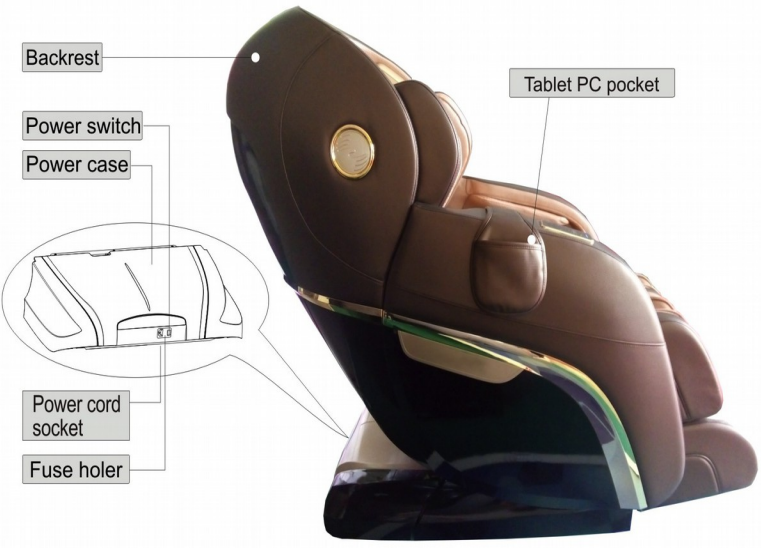

Internal structure

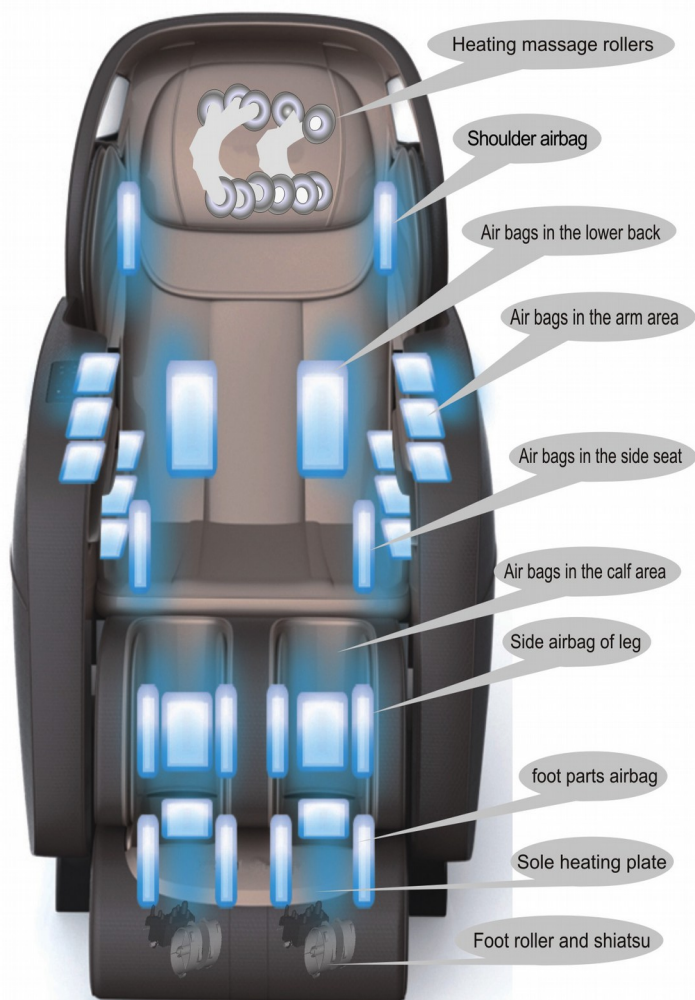



Explosion Diagram

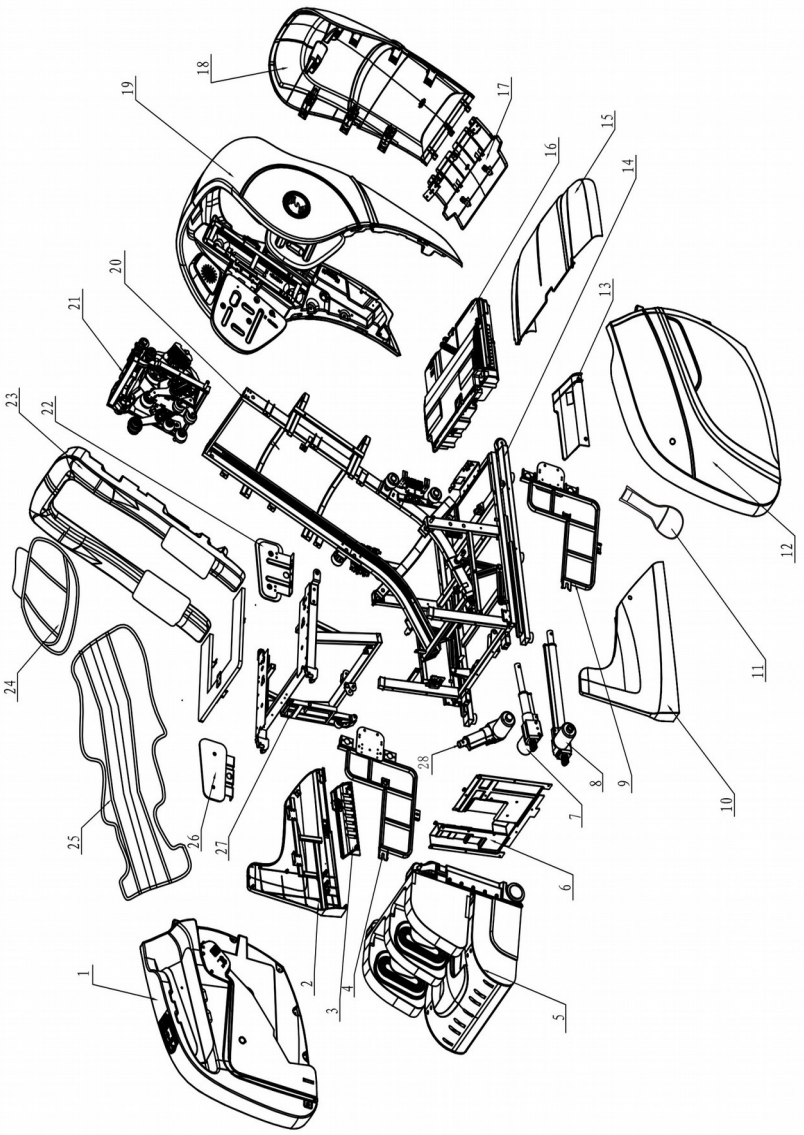

Mechanical components list

NO.	Name	Q' ty	NO.	Name	Q' ty
1	Right armrest assembly	1	22	Left side of seat airbag assembly	1
2	Right side fender	1	23	Backrest assembly	1
3	Right side of internal fender assembly	1	24	Pillow	1
4	Right armrest convert frame assembly	1	25	Back and seat cushion	1
5	Legrest and footrest assembly	1	26	Right side of seat airbag assembly	1
6	Front fender assembly	1	27	Seat frame surface assembly	1
7	Seat electric actuator	1	28	Footrest electric actuator	1
8	Sliding forward electric actuator	1			
9	Left armrest convert frame assembly	1			
10	Left side fender	1			
11	Tablet PC pocket	1			
12	Left amrest assembly	1			
13	Left side of internal fender assembly	1			
14	Seat bottom frame assembly	1			
15	Power box cover	1			
16	Power case assembly	1			
17	Back cover assembly A	1			
18	Back cover assembly B	1			
19	Shoulder device assembly	1			
20	Back frame assembly	1			
21	RK08 massage machine	1			



Installation (1)

1) Unpacking the main body of the chair

Remove the main body, back seat cushion, head pad, power cable, tablet PC, tablet PC pocket from the main body carton. Unpacking the massage chair body is best done with three people. Two lifting the left and right seat frame and one lifting from the back as shown below.

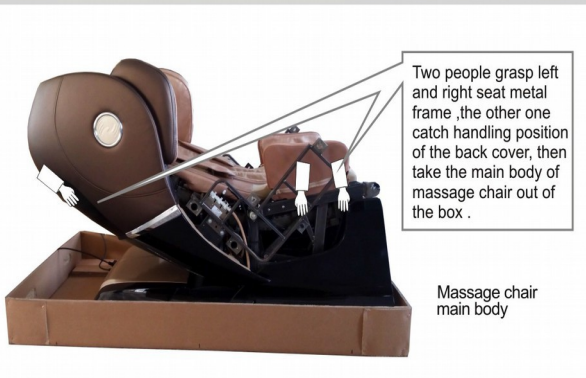

Head pad



Back seat cushion



Tablet PC



Tablet PC pocket



Electric power cable

2) Unpacking the arms

Take out the left and right armrest from the armrest box by grasping the two ends the armrests and lift them out slowly (the armrests are packed upside down in the box). Place armrests on a table or the floor carefully to avoid scratching the finish.



Right armrest



Left armrest

Installation (2)

3) Unpacking the footrest assembly

Remove the leg rest assembly from the main carton by grasping each side footrest and lifting slowly. Place on ground carefully to avoid scratches.

Legrest device



4) Leg rest installation

- Unscrew the bolts on the leg rest hangers
- Attach the air hose to the nozzle on the main chair body
- Firmly plug the power cables into their corresponding sockets on the chair body (black to black & white to white)
- Lift the leg rest assembly and position the pivot rods in the hanger brackets.
- Flip the pivot rod covers down and replace screws.
- Connect the leather leg rest flap to the chair with the velcro strip.

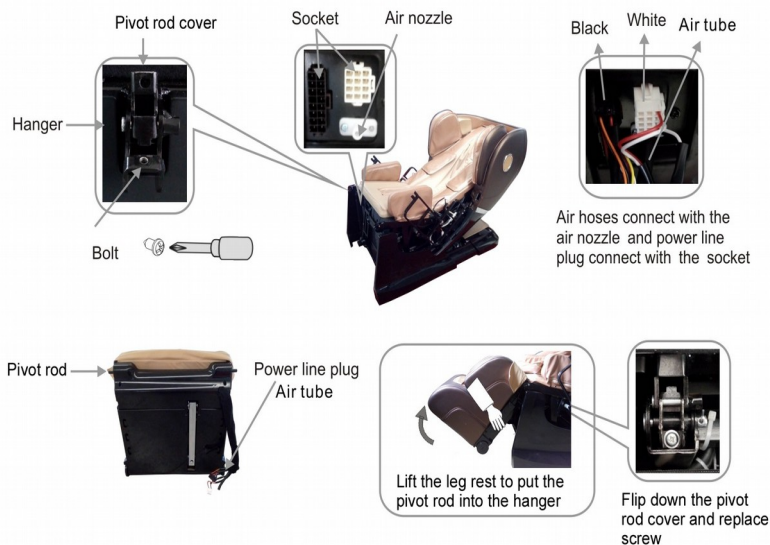

Installation (3)

4) Armrest installation

- a) Lift the front of the armrest and slide it into the rotating stand on the chair body.
- b) Connect the black air hose to air hose No. 1 and the grey air hose to air hose No. 2 on base.
- c) Plug the power cord from the chair body into the socket on the armrest.
- d) Install the rear fixed plate into the fixed hole on the chair body.
- e) remove the rubber plug from armrest inner plate, insert and tighten screw, replace rubber plug.
- f) Repeat with opposite side.

Important: Ensure the air hose and power cord are not pinched during installation.

Armrest removal

- 1) Fully recline back and lower footrest
- 2) Remove rubber plug and screw
- 3) Partially tilt the armrest upwards and disconnect air tubes and power cord
- 4) Continue to tilt armrest upwards to fully remove
- 5) Replace rubber plug

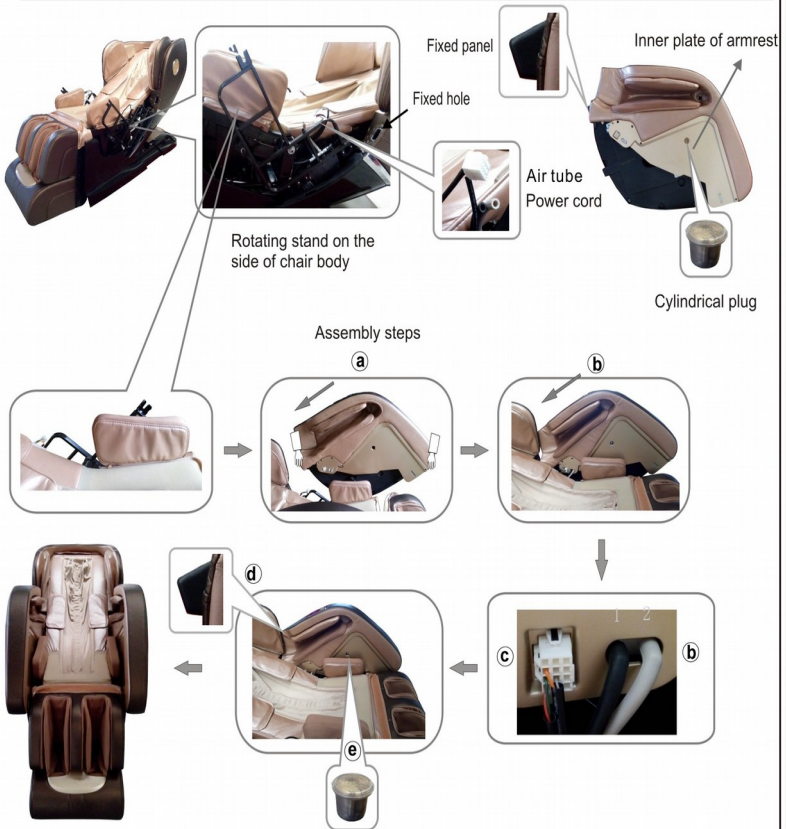

Installation (4)

5) Attach back & seat cushions, pillow & iPad pocket

Position the back, seat cushion & head pad onto the chair and connect using zipper and velcro.



Back seat cushion

Head pad



Tablet PC pocket

★ Tip:

In order to get the correct body test data and improve massage effect ensure the bottom rim of the head pad is flush with your ears before zippering.

Connect the pillow to the backrest by velcro

④

Backrest

② Back seat cushion connect to upper backrest by zipper

Head pad

Back seat cushion

③ Connect the back/seat cushion to the sides of chair back with zipper

③



Ensure the middle of the back/seat cushion aligns with the middle of the chair back

①

Connect the back/seat cushion to the chair seat with the zipper and velcro

⑤



Put the snap of the iPad pocket through the upper part of the right armrest air bag and snap it together

6) Power up the chair

- 1 Plug the power cord into the power box three prong socket
- 2 Plug power cord into the wall socket
- 3 Turn on main power switch (press L to turn on power and O to turn power off)
- 4 Press on/off button on the controller twice to begin. The chair will return to its initial state.

Select the massage function by control or iPad.
Enjoy the relaxing and pleasant massage.



Ensure the power switch is off before connecting power to the chair



Chair's initial state

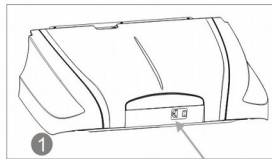

①

Power box socket



②

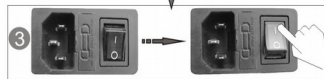

③



④



Environment

Caution



Don't use the chair in areas where it may become wet or there is high humidity to avoid shocks or malfunctions



To avoid upholstery wear and damage don't place in direct sunlight or near heat sources.



Please use chair on level surfaces to reduce noise and protect from accidental damage.

● Check places in front

Ensure areas around the chair are free of pets, children and other items before operating



● Check power cable, plug

Check power cord regularly for damage to avoid shocks or chair malfunction.

If there is any doubt about the safety of the power cord replace it before further use of the chair.



Check environment

● Space size for using the chair

- At least 10cm from wall.



- At least 30cm in front of the leg.

● Check surroundings

When the backrest or legrest reclines or extends, please pay attention to:

The areas in front and behind the chair to ensure there are no obstructions.



How to move massage chair



Caution

- ✦ To avoid injury or damage to the chair do not try to move it while it is in operation

How to move

- ✦ Unplug power cable and put on the seat
- ✦ If dropped or bumped too hard the inner mechanism of the chair may be damaged
- ✦ On wooden floors the casters may damage the floor. You may want to lift the chair instead of rolling it.
- ✦ Ensure the power is off and the power cord isn't dragging on the floor while the chair is being moved.



Normally

- 1 Lift by the leg rest to transfer the chair weight back onto the casters. Push the chair to the new location and lower the front of the chair back down to the floor.

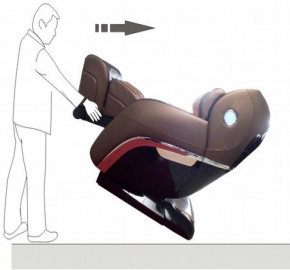

- ⚠ Grasp the footrest as shown above to avoid scratching the leatherette while moving the chair.

Adjustment before massage

● Before adjustment

- ✦ To avoid injury due to the massage head being in the wrong position, ensure the massage rollers are positioned at the top of the backrest before sitting gently into the chair.

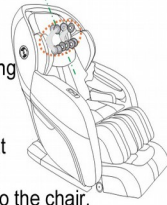

- ✦ When using acupuncture point position detection the default middle position will be the shoulders if auto detection can't detect the body position.

Correct Position: Your back rests against the back and the head rests against the pillow.

When the acupuncture point position detection starts, a prompt will display on the tablet PC. When the tablet PC controller sounds "adjustment for shoulder height position", the shoulder height can be fine tuned using the up and down buttons



- ✦ Ensure the massage head detection of your acupuncture point is correct to receive the best quality massage.

● Tips



- If the intensity of the massage is not strong enough, you can take off the pillow or cushion.
- This is a heavy chair and may cause indentations or marks on your floor. If you believe your floor is susceptible to damage placing some type of mat under the chair will help.



Manual control

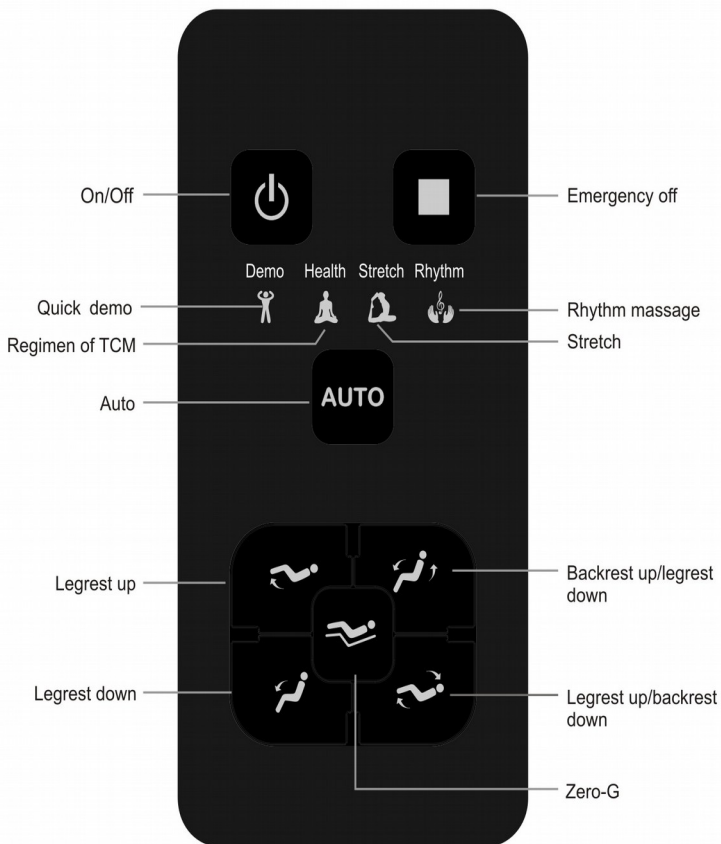







1. Press the on/off button to power up the chair for use and choose your program through the menu or massage keys. While powered on, pressing the on/off button will stop the massage and return the chair to the neutral position in "standby".



2. Press the stop button to stop all functions of the chair and disable all control buttons. To restart the chair the on/off button must be pushed to return power to the controls.



3. In "power on" mode, press this button to choose or change the auto program.

- ① quick demo,  light comes on, default working time is 8mins.
- ② Regimen of TCM,  light comes on, default working time is 20mins.
- ③ Stretch,  light comes on, default working time is 20mins.
- ④ Rhythm massage,  light comes on, default working time is 20mins.



4. Press and hold this button to raise the leg rest and release at the desired height. This function is not available in the stretch mode.



5. Press and hold this button to elevate the backrest and lower the footrest and release at the desired position. This function is not available in the stretch mode.



6. Press and hold this button to lower the legrest to the desired height and release. This function is not available in the stretch mode.



7. Press and hold this button to recline the backrest and raise the footrest and release at the desired position. This function is not available in the stretch mode.



8. In the "power on" mode pressing this button will move the chair to the Zero-Gravity position. Press the button again and the chair will return to the original position. This function is not available in the stretch mode.

Tablet/Smart Phone APPs

For control of your new massage chair please download the appropriate APP

Android: <https://www.factorydirectmedical.com/downloads/CH4000-Android-APP.apk>

iPhone/iPad: <https://itunes.apple.com/ca/app/massage-chair/id1018690700?mt=8>

(Note: Apple version of app is labelled "Rokol 8900A MassageChair" on iTunes.)



Tablet computer illustration

Boot screen



1. Display chair picture, it is available to slide the chair picture.

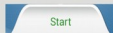

2. Press this key to enter main interface.

Main interface.

1. ON/OFF key.
2. Emergency stop key.
3. Time display.



4. Display width, speed, strength, and foot massage status.

Auto

5. Press this key to choose auto program:

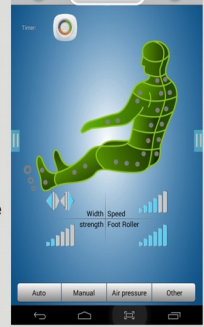

traditional chinese massage, pain relief, stretch, quick demo, relax, health care, rhythm massage, white-collar, shopholic, back yoga, athlete mode, care of aged

Manual

6. Press this key to choose massage method, position, speed, width, 4D hand feeling function.

Air pressure

7. Press this key to choose air pressure massage position manually.

Other

8. Press this key to choose foot roller, foot heating, back heating, music function.

Auto massage function: In boot screen status, press **Auto** will switch to Auto program screen, there are 12 kinds of Auto programs for choice.



1. In ON status, press this key enter into "Regimen of TCM" auto program, icon light up at this time; Default working time is 20 minutes.



2. In ON status, press this key enter into "Longevity and health" auto program, icon light up at this time; Default working time is 20 minutes.



3. In ON status, press this key enter into "Rhythm massage" auto program, icon light up at this time; Default working time is 20 minutes. Massage machine change massage speed according to music rhythm.



4. In ON status, press this key enter into "back yoga" auto program, icon light up at this time; Default working time is 20 minutes.



5. In ON status, press this key enter into "athlete mode" auto program, icon light up at this time; Default working time is 20 minutes.



6. In ON status, press this key enter into "Relax" auto program, icon light up at this time; Default working time is 20 minutes.



7. In ON status, press this key enter into "Health care" auto program, icon light up at this time; Default working time is 20 minutes.



8. In ON status, press this key enter into "Pain relief" auto program, icon light up at this time; Default working time is 20 minutes.

Auto program interface 1

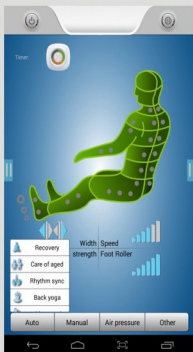

Auto program interface 2

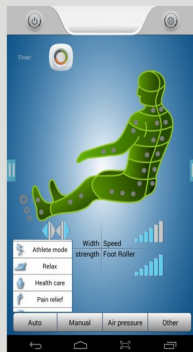

Tablet computer illustration

Auto program interface 3



9. In ON status, press this key enter into "Quick demo" auto program, icon light up at this time; Default working time is 8 minutes.
10. In ON status, press this key enter into "Stretch" auto program, icon light up at this time; Default working time is 20 minutes.
11. In ON status, press this key enter into "shopaholic" auto program, icon light up at this time; Default working time is 20 minutes.
12. In ON status, press this key enter into "White-collar" auto program, icon light up at this time; Default working time is 20 minutes.

Note: The standard automatic programs all include these features

- 1) For those with shoulder height detection the detection is done only once.
- 2) All programs position the chair automatically to the suitable position at the beginning. If the position is adjusted before choosing the program the chair will not automatically position itself to the preprogrammed position.

Manual Message Function: On the boot screen status, pressing **Manual** will switch you to the manual program screen. There are 5 choices: Mode, Position, Width, Speed, 4D hand sensation. After making your choice a new menu will appear where you can choose between message method, position, width, speed and 4D function.

- Mode:** Pressing the "Mode" key will display 5 kinds of massage techniques: Kneading, Knocking, Tapping, Kneading & Tapping or Shiatsu. Massage techniques will proceed with the default settings including shoulder height detection if shoulder height detection was not completed previously.

Manual interface — Mode

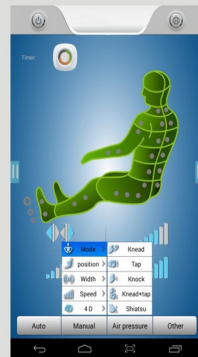

Manual interface — Position

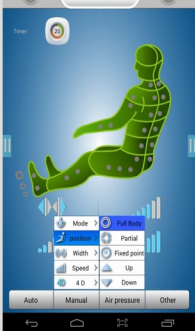

- Position:** Pressing the "Position" key will display 5 choices: Overall, Fixed, Point, Up or Down.

"**Partial**" will provide a up and down reciprocating motion within a certain scope. This function does not require shoulder height detection. If the position is changed during shoulder height detection the detection function will stop and the program will proceed with the choice made.

"**Fix**" will stop the massage in the current position and can be adjusted up or down as needed.

Width: This function can only be chosen in the manual mode. It will adjust width when knocking, tapping and shiatsu massage types only.

Speed: This function can only be chosen in the manual mode.

Manual interface — Width

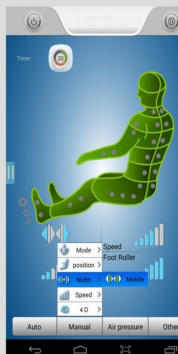

Manual interface — Speed

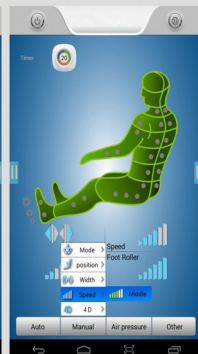

Tablet computer illustration

Manual mode –4D

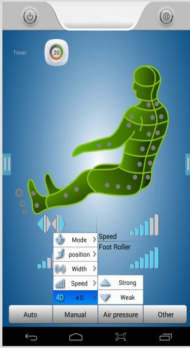

4D 4D Hand Sensation: This function can only be chosen in manual mode. The two options are 4D Plus and 4D Minus. (Shiatsu excepted).

Controls the intensity of the massage by adjusting the pressure exerted by the rollers. The higher the pressure the more deeply they will push into the body.

Air Pressure Function: When pressed,

Air pressure button will take you to air pressure screen with 4 choices: Overall, Armrest & Shoulder, Waist & Seat, leg rest and footrest. Once option is selected the next menu will offer a choice of strengths.

Air pressure screen

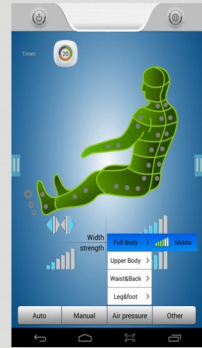

Full Body >

1. Press this button to massage your whole body by air pressure and roller massage.

Upper Body >

2. Press this button to massage your arms and shoulders with air pressure.

Waist&Back >

3. Press this button to massage your waist and seat by air pressure.

Leg&foot >

4. Press this button to massage your lower legs and feet by air pressure and roller massage.

Width strength

5. Press this button to adjust the strength of the air pressure.

Other interface

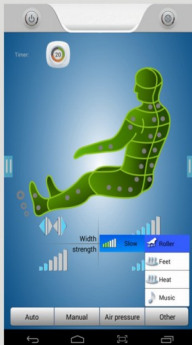

Other Function: With power on press **Other** to enter other massage menu with 4 choices. Roller, Feet heating, Heat or Music

Roller

1. Press to enter foot massage therapy. Choice of soft or fast massage intensity. Press stop to end the function.

Feet

2. Press to start or stop heat on soles and massage function.

Heat

Music

3. Press to play music through speakers.

Slow

4. Press to adjust foot roller massage speed.

Tablet computer illustration

Adjust the position of body

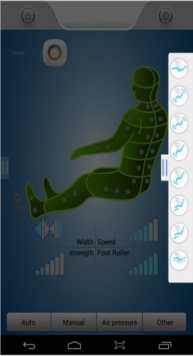



Position Adjustment: Press right key  under the main interface, change to position adjustment interface, eight position for choice.

1. Sleeping position: Press this button, massage chair will go into sleeping position. Press it again to return to original position.
2. Legrest down and backrest up: Keep pressing this button, backrest goes up, legrest goes down. Release it, backrest and legrest stop moving.
3. Legrest up and backrest down: Keep pressing this button, backrest goes down, legrest goes up. Release it, backrest and legrest stop moving.
4. Legrest up: Keep pressing this button, legrest goes up, release it, legrest stop moving.
5. Legrest down: Keep pressing this button, legrest goes down, release it, legrest stop moving.
6. Legrest retraction: Press this button, legrest draws back, and release this button, legrest stop drawing back.
7. Legrest Extend: Press this button, legrest stretching out, and release this button, legrest stops stretching out.
8. Zero gravity: Press this button, massage chair will go into zero-gravity position. Press it again to return to original position.

Note: During the Stretch, Relax and Health Care modes the chair position can not be changed.

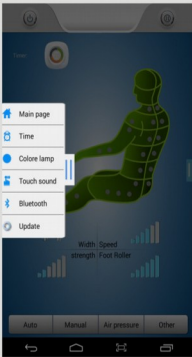
Setting interface



Setting Function: Press the left key  under main interface to change to one of 6 settings: Main Page, Time, Colour Lamp, Touch Sound, Update.

1. Press this key to return to home page.
2. Press this key to set time of 10 min., 20 min. or 30 min. Massage will turn off automatically after set time interval.
3. Press this key to turn LED lights on or off.
4. Press this key to turn voice notification on or off.
5. Press this key to turn Bluetooth on or off.
6. Press this key to update app from the internet.

We reserve the right for tablet computer interface design modification and authority. It is subject to change without notice. The pictures in this manual are only for reference. Please refer to the actual product. For details, please refer to electric edition file.

ON/OFF

Step1. Power on

- ① Put one end plug of power line to "a" hole.
- ② Put power plug to socket.
- ③ Turn on the power switch which is on the power box, massage chair is powered.

Step2. Massage

- ① Refer to remote control or tablet operate instruction, choose the massage function which you needed. Massage method details, please refer to remote control or tablet manual book .
- ② When massage stop, the massage machine will reset and tablet will show shutting down,

Convenient remote control Tablet

- ①
- ②
- ③

Step3. Turn off the power

- ① When the chair is On, press On/Off button to turn off the massage chair and it will restore automatically.
- ② Turn off the power switch on the bottom of the back of chair after the rollers stay at storage position.
- ③ Unplug the power plug from the socket.

Warning

1. Before using, pull up the pillow, back cushion etc. to check if the PU material is broken, if there is damage, please stop using, unplug the chair, and ask for repairment.
2. Only plug to proper socket.

Attention

1. Before sitting down, make sure there is no things pinched between armrest, legrest, backrest and seat of the chair.
2. Make sure the chair is in returned position before using.
3. Do not stand on it when using the massage chair.

Function Illustration

● Legrest Up

Press this button on controller, legrest goes up. Release the button, legrest stops moving, the angle is locked in this position.



● Legrest Down

Press this button on controller, legrest goes down. Release the button, legrest stops moving, the angle is locked in this position.



● Legrest up and backrest down

Press this button on controller, backrest go down and legrest go up. Release this button, backrest and legrest stop moving, the angle is locked in this position.



● Backrest up and Legrest down

Press this button on controller, backrest go up and legrest go down. Release this button, backrest and legrest stop moving, the angle is locked in this position.



● Zero gravity

Press the remote control button, the back down, the legrest up. adjust the angles can go into the Zero gravity. Press the button again, the back up and legrest down, the chair return to the reset.



★ Tips: Zero-gravity is according to the NASA Space capsule relax theory, through the back, seat, legrest three sections multi angle changeable,



making the legrest up and seat down can make the angle 128 (+/-7) degrees between Body and legrest. Let the heart and knee at the same level, reducing the blood circulation pressure to the lowest, but all the body pressure will put on the buttocks, and because of the ZERO GRAVITY position design, increase the forced area from the body and massage chair, so all the forces can be dispersed to the massage chair, reducing heart and spine pressure, realizing the best Zero gravity massage experience. creating a completely relax, natural and comfortable massage posture.



1. Please ensure there are no people, pets or anything else within the range the chair backrest to avoid damage or injury.
2. When adjusting the backrest angle be careful nothing gets caught between the backrest and armrest.
3. Do not exit the chair while the leg rest is moving. Physically stopping the leg rest will damage the chair and may cause injury.
4. Please refer to control instructions for more information.



Function Illustration

● Legrest extend and retract

Legrest can extend and retract within 20cm automatically.



● Arm massage

Massage chair use space capsule type armrest, with built-in pulse air pressure massage function. Put the arms between armrest's air bags. After filling air, achieve kneading massage on the arms and hands. The arms could get comfortable massage in any angle of the chair.



● Shoulder massage

Multi-layer extrusion type air bags on both sides of the shoulder, realize stretch function. The 4D massage machine push your body when air pressure massage on shoulder, realizing body stretch function.



● Warm foot therapy

Innovatively developed two-way rotary foot kneading technique, realizing the sole function of kneading foot, combining with foot heating, it can perform best foot massage experience, good for health.



● New Curve rail, Combination of back and buttocks massage.

Massage chair adopts 4D curved rail technology, combining with 4D massage mechanism patent, realizing multi-angle integrated massage for back and buttocks. It has broken through traditional L shape rail's function which can't realize lying flat and stretching, and achieve best massage effect.

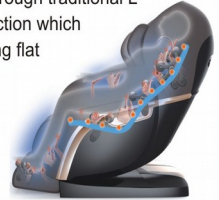

● Music therapy

With two high quality loudspeakers by the side of the head, you could select music function through tablet controller, use music player to control the music or play MP3 music. It massages according to music rhythm.



1. Please ensure there are no people, pets or anything else within the range the chair backrest to avoid damage or injury.
2. When adjusting the backrest angle be careful nothing gets caught between the backrest and armrest.
3. Do not exit the chair while the leg rest is moving. Physically stopping the leg rest will damage the chair and may cause injury.
4. Please refer to control instructions for more information.

Restoration of massage chair

- 1 Make sure there is no people or pet or anything within the range of backrest and legrest.



- 2 Make backrest and legrest restore to the normal position by controller.(or press ON/Off key to make backrest and legrest restore to the normal position)



- 3 Adjust the back cushion and pillow to the original position.



- 4 After the chair returning to the original position, put the tablet controller into packet which is on the right armrest

- 4 Switch off the power.

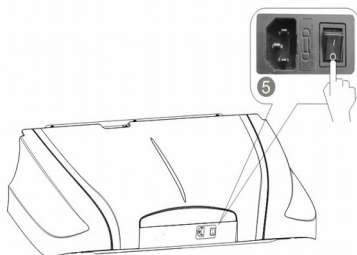

- 5 Unplug the electricity from the socket. (Attention: hold the right plug position)



- 6 Clean the chair if necessary.



Attention!

- After using, press ON/OFF to end all the massage method and wait for restoration. Make sure to cut the electricity to avoid any unexpected hurt to children or pets.
- After using, turn off the power, unplug the electricity. Avoid moisture, dirt and aging of insulation in case of causing damage.

Synthetic leather

● General cleaning

Wipe down using a dry soft cloth to remove dust.



(Chemical or medical cleaning products are forbidden)



Forbidden



● If leather is dirty

- 1 Dip soft cloth into 3-5% neutral detergent solution, squeeze it then clean the stain on the surface gently.
- 2 Wash cloth, squeeze it and wipe with detergent.



- 3 Clean it softly with dry cloth.
- 4 Allow to dry (air blower is prohibited)

Plastic parts

- 1 Dip cloth into neutral detergent, squeeze it and clean.
- 2 Wipe with water-dipped but squeezed cloth.
- 3 Allow to dry.



Clean the controller

- 1 Wipe with soft cloth after squeezing.
- 2 Allow to dry.
Propellant, diluent or alcohol are prohibited.



Forbidden



Convenient remote control



Tablet remote control

Cloth material

- 1 Dip cloth into weak neutral detergent, squeeze it and clean the material surface.
- (Diluent, gas, alcohol are prohibited)
Brush the dirty parts with weak neutral detergent. (avoid excessive brushing)
- 2 Excessive cleaning may cause damage to cloth material.
- 3 Wipe with water-dipped but squeezed cloth.
- 4 Allow to dry.



Forbidden



About cleaning

- Before cleaning, unplug the electricity, don't touch plug with wet hands.
- Make sure hands are dry when plugging to the socket.
- Failure to follow instructions may lead to burns or electric shock

FAQ and Troubleshooting

Trouble	Possible reason	Troubleshooting
Massage Chair doesn't work	Chair not turned on	Turn on main power switch
	No massage function chosen	Choose massage function
	Check whether the plug and socket in poor contact.	Make sure plug and socket are connected.
	Wire or plug has damaged.	Please ask manufacturer or appointed or authorized maintenance man for checking and replacement.
	The fuse burned out.	Replace fuse of same specification.
	Something wrong with inner circuit	Please ask appointed or authorized maintenance man for checking and repairing.
There is beep sound inside the massager while working.	It is sound of air pump, motor and mechanical parts.	Normal sound, no need to pay attention to it.
Different height of the left roller and right roller.	Massage rollers work on shifts.	Normal, no need to pay attention to it.
Sound suddenly becomes much louder while working.	Check if it is due to long time working.	Turn off the power to have the massager rest for over half an hour before next turn working.
	Inner parts fretted away due to long time work. It's normal	Please ask appointed or authorized maintenance man for checking and repairing.
Massage function suddenly stops while working.	Suddenly power-down	Connect the electricity power again
	Setting time is up.	Turn off the power to have the massager rest for over half an hour before next turn working.
Neither the backrest nor the legrest can be lay down.	Check if there are any obstacles; the chair overloads; for the sake of safety, sometimes the massage machine may automatically stop working.	Remove the obstacles; turn off the power to have the massager rest for over half an hour before next turn working.
The chair can't return to its original position.	Excessive operation; setting time is up.	Please ask manufacturer or appointed or authorized maintenance man for checking and replacement.
Electric wire or plug give out heat	It may work overload	Turn off the power to have the massager rest for over half an hour before next round working.
	Other abnormal case	Stop using, and ask appointed maintenance man for help.



Note: If the troubles are not caused by above reasons, please turn off the power switch and cut off the power, then contact the manufacturer or service agent to repair your chair.



Technical data

Name	4D Full Body Massage Chair	Power	280W
Model	CH4000	NW/GW	Main body :115/137 kg Armrest :14.5/19.5 kg Legrest &footrest : 30/34.5 kg
Input voltage	<input checked="" type="checkbox"/> AC120V, 60Hz <input type="checkbox"/> AC220V, 50/60Hz <input type="checkbox"/> AC240V, 50Hz		
Safety design	Class I	Packing size	Main body: 1520×795×970 mm Armrest : 980×395×715 mm Legrest &footrest :585 × 515 × 620 mm (L×W×H)

Imported / Distributed by:

Factory Direct Medical
34 Futurity Gate, Unit # 15
Concord Ontario L4K 1S6
Local: 416-739-8393
Toll Free: 855-235-2400